

PROCEDURE IN THE EVENT OF A POWER FAILURE TO RESTORE YOUR WIRELESS DECODERS AND MAKE SURE IT IS FUNCTIONAL AGAIN

IMPORTANT! In the event of a power failure, unplug all decoders from the power supply.

When electricity comes back, wait for your Gigacenter to be functional again, which also means your internet service must be functional. You can be sure your Gigacenter is operational when you see LED lights on, such as seen on this picture:

- 1 The top 5 lights must be on.
- 2 The ETHERNET 1 light must be on, which indicates that there is an equipment plugged in the socket # 1 (yellow) at the back of the Gigacenter (it could be a computer connected by network cable or a wired decoder).

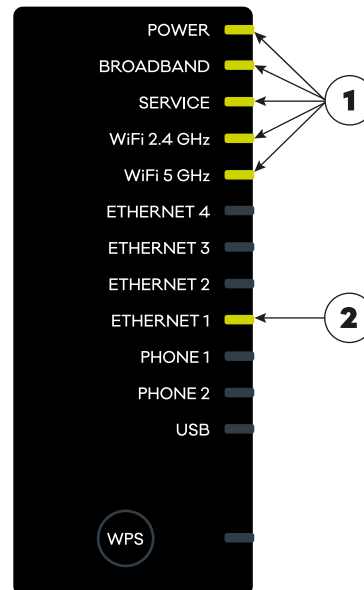

Once you have verified those lights, you can reconnect your wireless decoders.

If the lights on your Gigacenter are not all on, even after waiting a while, please contact our technical support.

If you see this image on your screen:

Make sure your Gigacenter is functional (as shown above). If so, unplug the power chord of your decoder and plug it back in.

This image appears when your decoder starts up faster than the Gigacenter after a power failure. Your decoder is therefore looking for a functional network and you are asked to choose one. In fact, no action is required but to unplug the decoder and plug it back in again; the decoder will search for the right network on your Gigacenter by itself.

